

SURFACE AREA OF:

PRISMS AND CYLINDERS

PYRAMIDS AND CONES

SPHERES

LATERAL AREAS AND SURFACE AREAS OF PRISMS

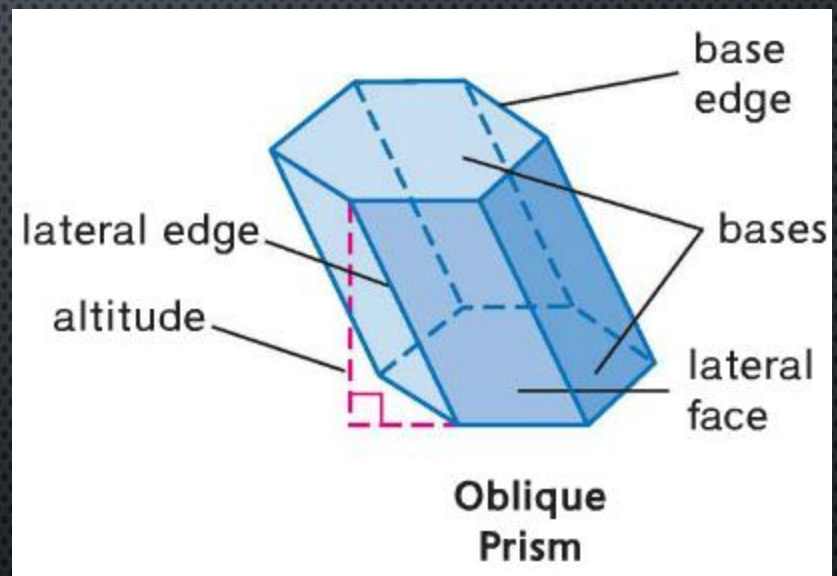
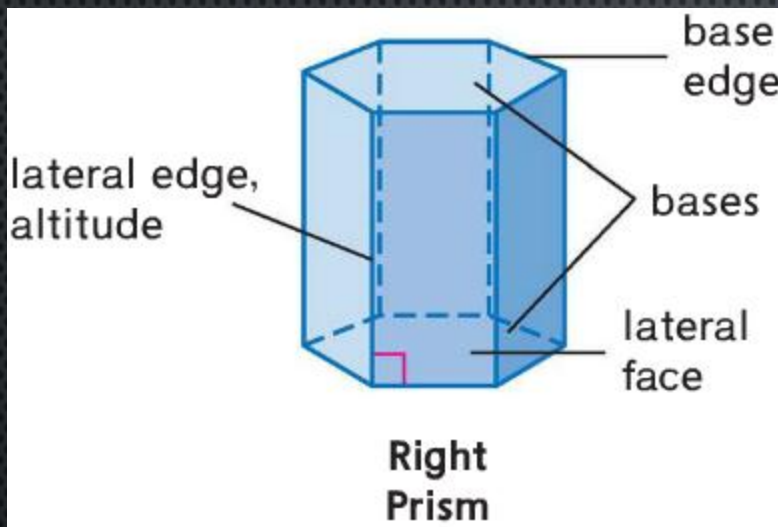

LATERAL AREA OF A PRISM

- THE LATERAL AREA L OF A RIGHT PRISM IS $L=Ph$, WHERE h IS THE HEIGHT OF THE PRISM AND P IS THE PERIMETER OF A BASE.

SURFACE AREA OF A PRISM

- THE SURFACE AREA S OF A RIGHT PRISM IS $S = L+2B$, WHERE L IS THE LATERAL AREA AND B IS THE AREA OF A BASE.

EXAMPLES

- FIND THE SURFACE AREA OF THE PRISM.

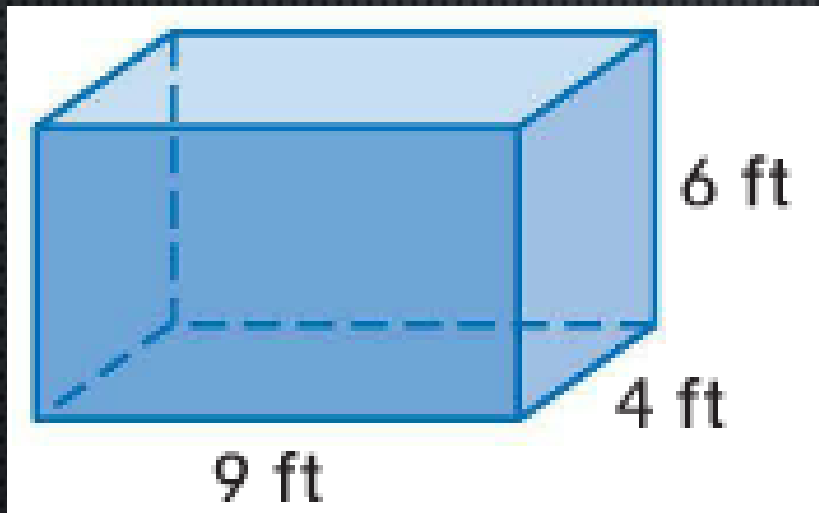

EXAMPLES

- FIND THE SURFACE AREA OF THE PRISM.

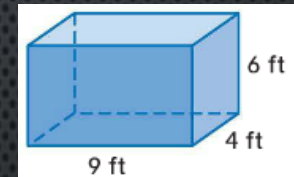

- $S = L + 2B; L = PH \rightarrow S = PH + 2B$
- $P = 2L + 2B = 2(4) + 2(6) = 8 + 12 = 20$
- $B = 6 * 4 = 24; H = 9$
- $S = (20)(9) + 2(24)$
- $= 180 + 48$
- $= 228$

LATERAL AREAS AND SURFACE AREAS OF CYLINDERS

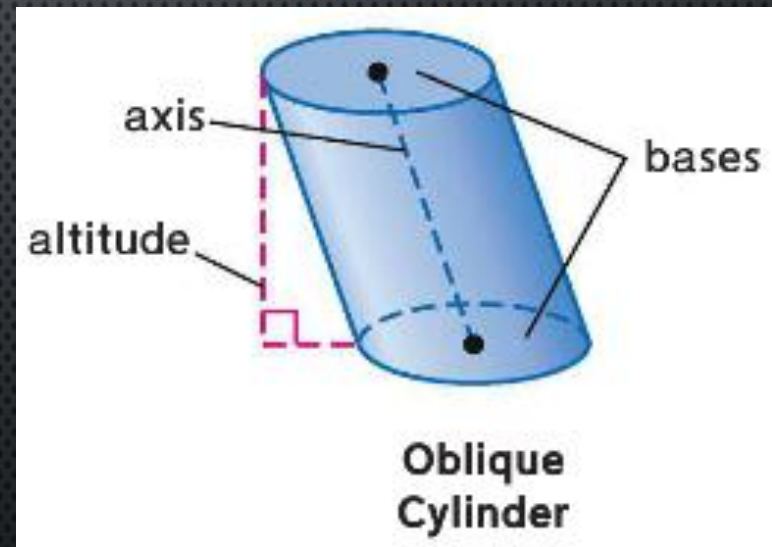
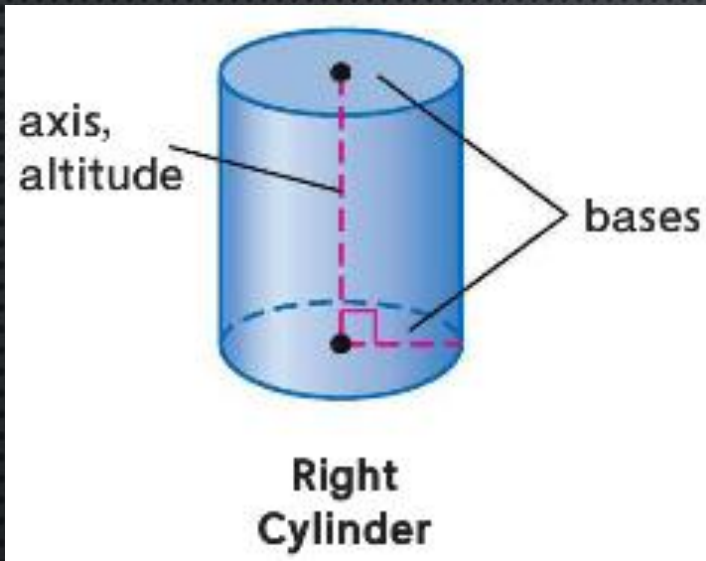

LATERAL AREA OF A CYLINDER

- THE LATERAL AREA L OF A RIGHT CYLINDER IS $L = 2\pi rH$, WHERE r IS THE RADIUS OF A BASE AND H IS THE HEIGHT.

SURFACE AREA OF A CYLINDER

- THE SURFACE AREA S OF A RIGHT CYLINDER IS

$$S = 2\pi RH + 2\pi R^2,$$

WHERE R IS THE RADIUS OF A BASE AND H IS THE HEIGHT.

EXAMPLES

- FIND THE LATERAL AREA AND THE SURFACE AREA OF THE CYLINDER. ROUND TO THE NEAREST TENTH.

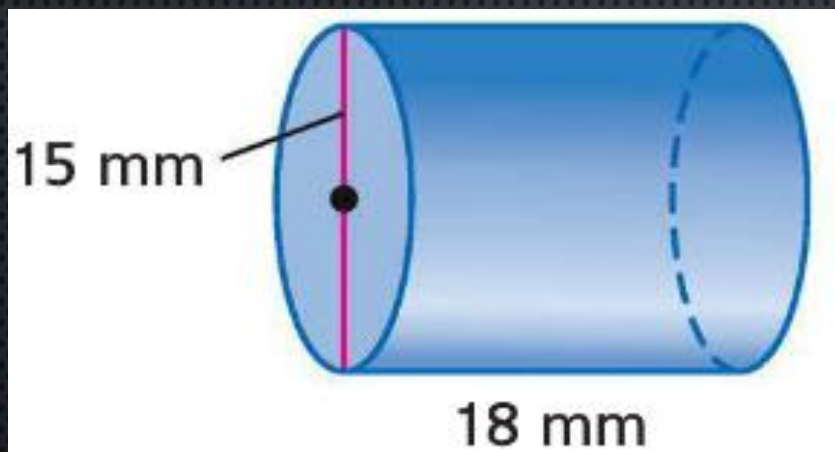

EXAMPLES

- FIND THE LATERAL AREA AND THE SURFACE AREA OF THE CYLINDER. ROUND TO THE NEAREST TENTH.

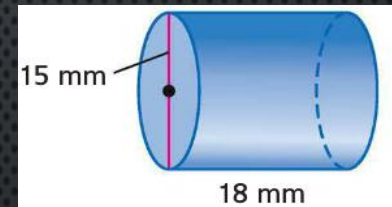

- $L = 2\pi RH$; $R = \frac{15}{2} = 7.5$, $H = 18$
- $L = 2\pi(7.5)(18) = 270\pi = 848.2$
- $S = L + 2B$; $B = \pi R^2$
- $S = 270\pi + \pi(7.5^2)$
- $S = 270\pi + 56.25\pi = 326.25\pi = 1024.9$

PYRAMIDS

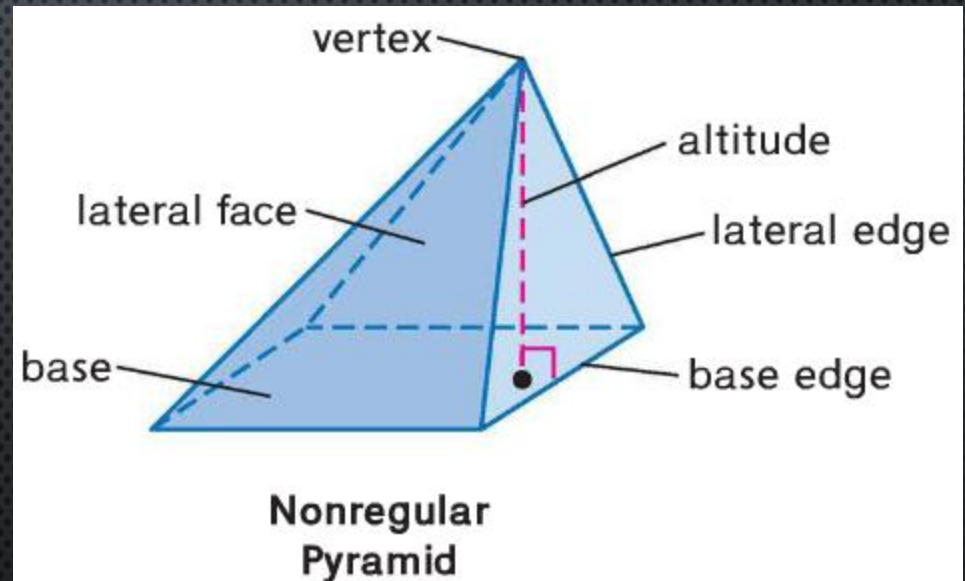
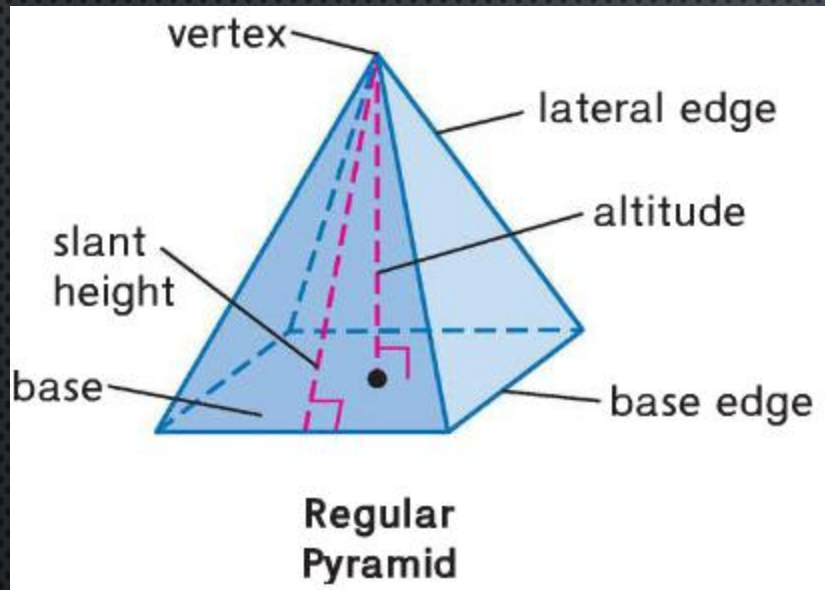

LATERAL AREA OF A REGULAR PYRAMID

- THE LATERAL AREA L OF A REGULAR PYRAMID IS $L = \frac{1}{2}P\ell$, WHERE P IS THE PERIMETER OF THE BASE AND ℓ IS THE SLANT HEIGHT.

EXAMPLES

- FIND THE LATERAL AREA OF THE SQUARE PYRAMID.

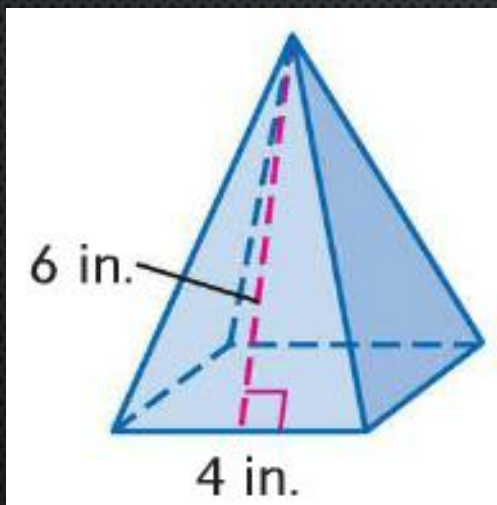

EXAMPLES

- FIND THE LATERAL AREA OF THE SQUARE PYRAMID.

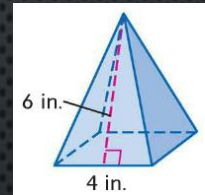

- $L = \frac{1}{2}P\ell; P = 4 * 4 = 16; \ell = 6$
- $L = \frac{1}{2}(16) * (6) = 48$

SURFACE AREA OF A REGULAR PYRAMID

- THE SURFACE AREA S OF A REGULAR PYRAMID IS $S = \frac{1}{2}P\ell + B$, WHERE P IS THE PERIMETER OF THE BASE, ℓ IS THE SLANT HEIGHT, AND B IS THE AREA OF THE BASE.

EXAMPLES

- FIND THE SURFACE AREA OF THE PYRAMID TO THE NEAREST TENTH.

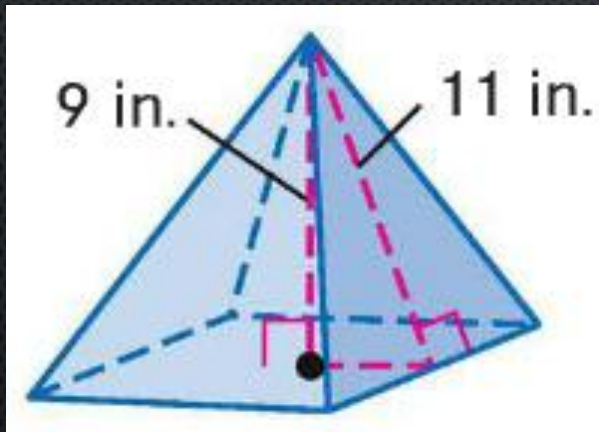

EXAMPLES

- FIND THE SURFACE AREA OF THE PYRAMID TO THE NEAREST TENTH.

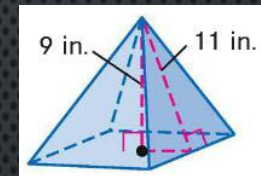

- $S = \frac{1}{2}P\ell + B$
- $11^2 - 9^2 = 40; \sqrt{40} = \frac{1}{2}s \rightarrow s = 2\sqrt{40} = 4\sqrt{10}$
- $P = 4 * 4\sqrt{10} = 16\sqrt{10}; B = (4\sqrt{10})^2 = 160$
- $S = \frac{1}{2}(16\sqrt{10})(11) + 160$
- $S = 438.3$

EXAMPLES

- FIND THE SURFACE AREA OF THE REGULAR PYRAMID TO THE NEAREST TENTH.

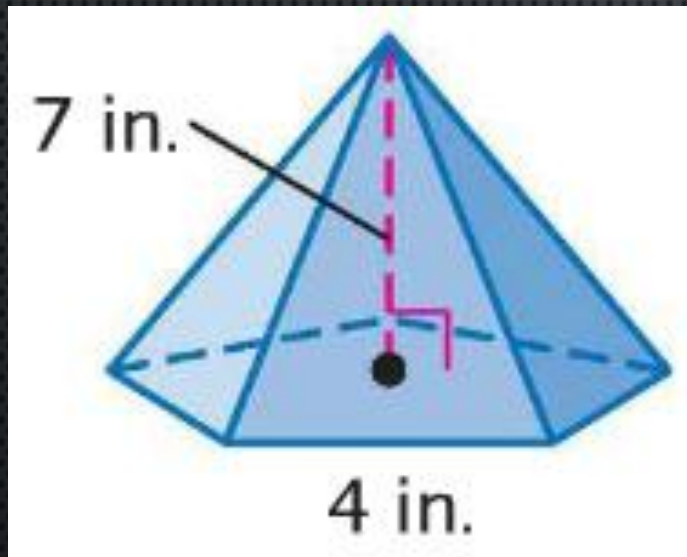

EXAMPLES

- FIND THE SURFACE AREA OF THE REGULAR PYRAMID TO THE NEAREST TENTH.

- $S = \frac{1}{2}P\ell + B$; $P = 4 * 5 = 20$
- $B = \frac{1}{2}PA = \frac{1}{2}(20)(2.75) = 27.5$
- $\ell = \sqrt{2.75^2 + 7^2} = 7.5$
- $S = \frac{1}{2}(20)(7.5) + 27.5$
- $S = 102.5$

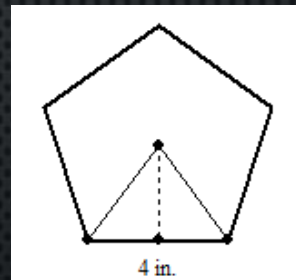
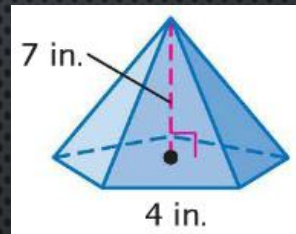

LATERAL AREA AND SURFACE AREA OF CONES

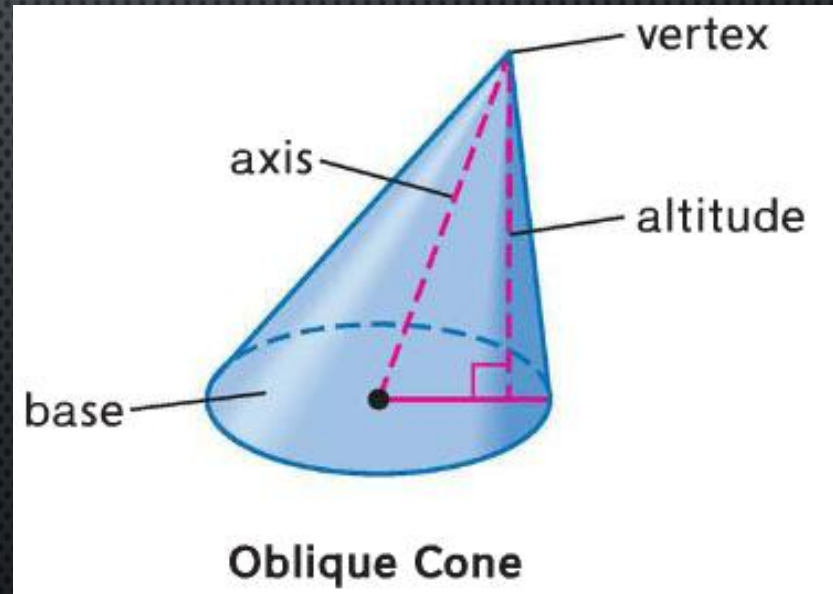
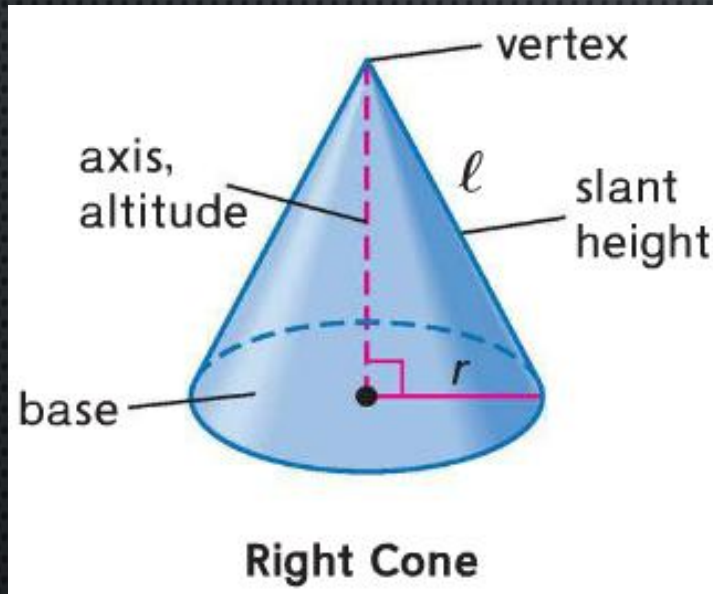

LATERAL AND SURFACE AREA OF A CONE

- THE LATERAL AREA L OF A RIGHT CIRCULAR CONE IS $L = \pi R \ell$, WHERE R IS THE RADIUS OF THE BASE AND ℓ IS THE SLANT HEIGHT.
- THE SURFACE AREA S OF A RIGHT CIRCULAR CONE IS $S = \pi R \ell + \pi R^2$, WHERE R IS THE RADIUS OF THE BASE AND ℓ IS THE SLANT HEIGHT.

EXAMPLES

- FIND THE LATERAL AND SURFACE AREA OF A CONE WITH A DIAMETER OF 14.8 CENTIMETERS AND A SLANT HEIGHT OF 15 CENTIMETERS.

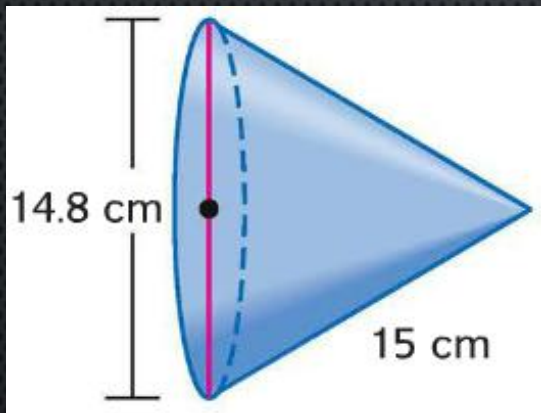

EXAMPLES

- FIND THE LATERAL AND SURFACE AREA OF A CONE WITH A DIAMETER OF 14.8 CENTIMETERS AND A SLANT HEIGHT OF 15 CENTIMETERS.

- $L = \pi R \ell; R = \frac{14.8}{2} = 7.4;$

- $L = \pi(7.4)(15) = 111\pi = 348.7$

- $S = \pi R \ell + \pi R^2$

- $S = 111\pi + \pi(7.4^2)$

- $S = 111\pi + \pi(54.76) = 165.76\pi = 520.75$

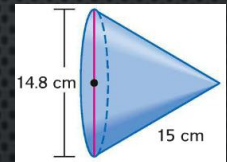

EXAMPLES

- FIND THE LATERAL AND SURFACE AREAS OF THE CONE. ROUND TO THE NEAREST TENTH.

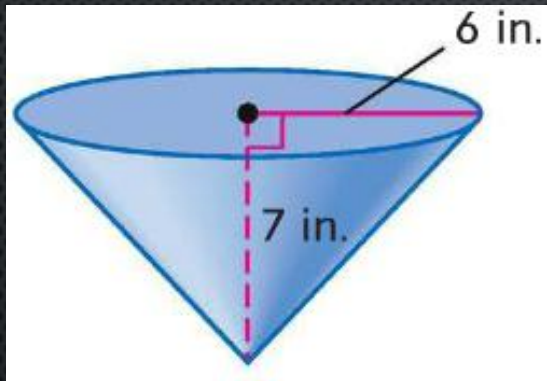

EXAMPLES

- FIND THE LATERAL AND SURFACE AREAS OF THE CONE. ROUND TO THE NEAREST TENTH.

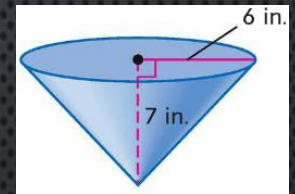

- $L = \pi R \ell$; $R = 6$;
- $\ell = \sqrt{6^2 + 7^2} = 9.2$
- $L = \pi(6)(9.2) = 55.2\pi = 173.4$

- $S = \pi R \ell + \pi R^2$
- $S = 55.2\pi + \pi(6^2)$
- $S = 55.2\pi + \pi(36) = 91.2\pi = 286.5$

SURFACE AREA OF A SPHERE

- THE SURFACE AREA S OF A SPHERE IS $S = 4\pi R^2$, WHERE R IS THE RADIUS.

EXAMPLES

- FIND THE SURFACE AREA OF THE SPHERE TO THE NEAREST TENTH.

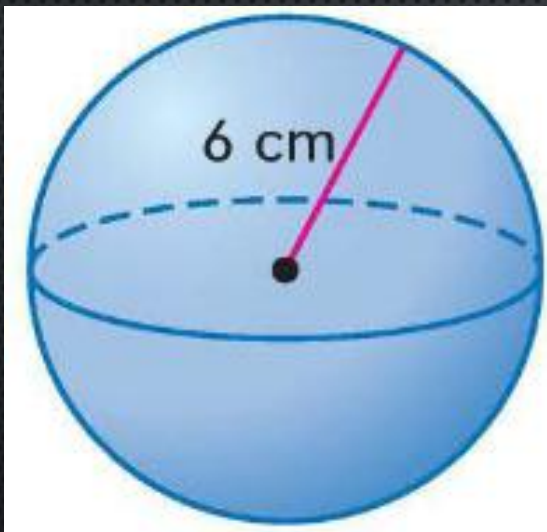

EXAMPLES

- FIND THE SURFACE AREA OF THE SPHERE TO THE NEAREST TENTH.

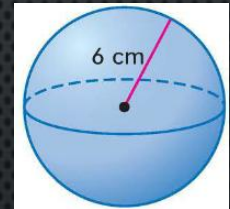

- $S = 4\pi R^2; R = 6 \rightarrow 4\pi(6)^2$
- $S = 144\pi = 452.4$

EXAMPLES

- FIND THE SURFACE AREA OF THE SPHERE TO THE NEAREST TENTH.

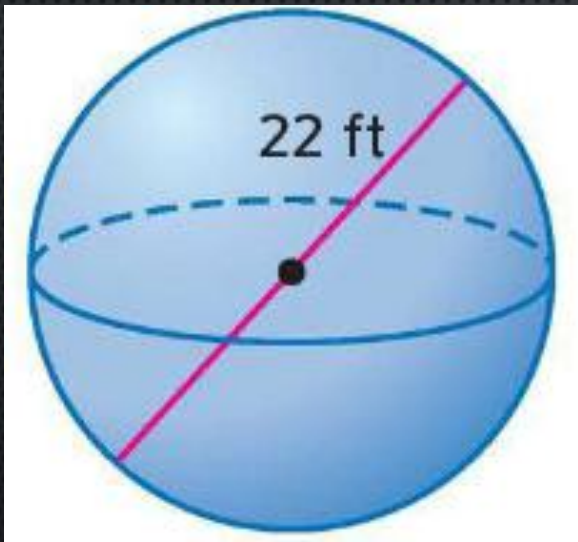

EXAMPLES

- FIND THE SURFACE AREA OF THE SPHERE TO THE NEAREST TENTH.

- $S = 4\pi R^2$; $R = \frac{22}{2} = 11 \rightarrow S = 4\pi 11^2$

- $S = 484\pi = 1520.5$

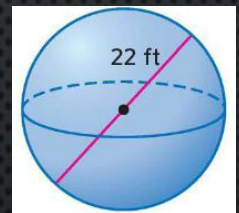

SPHERES

- A PLANE CAN INTERSECT A SPHERE IN A POINT OR IN A CIRCLE.

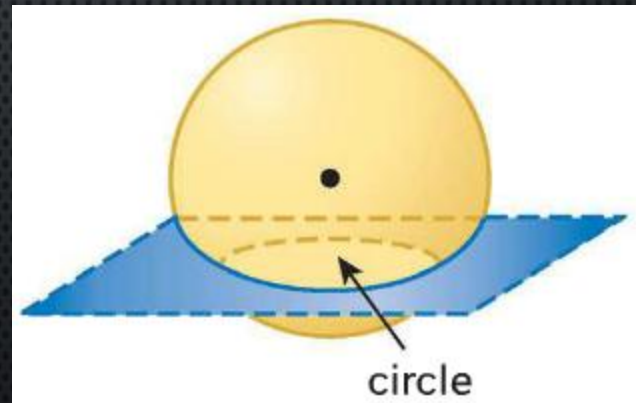
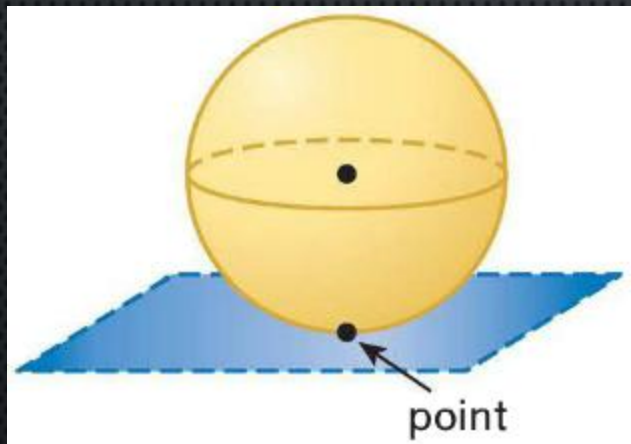

SPHERES

- IF THE CIRCLE CONTAINS THE CENTER OF THE SPHERE, THE INTERSECTION IS CALLED A GREAT CIRCLE.
- THE ENDPOINTS OF A DIAMETER OF A GREAT CIRCLE ARE CALLED POLES.

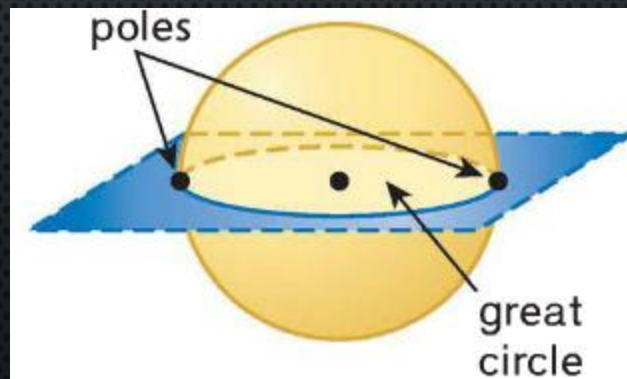

GREAT CIRCLE

- SINCE A GREAT CIRCLE HAS THE SAME CENTER AS THE SPHERE AND ITS RADII ARE ALSO RADII OF THE SPHERE, IT IS THE LARGEST CIRCLE THAT CAN BE DRAWN ON A SPHERE.
- IT SEPARATES A SPHERE INTO TWO CONGRUENT HALVES, CALLED HEMISPHERES.

EXAMPLES

- FIND THE SURFACE AREA OF THE HEMISPHERE.

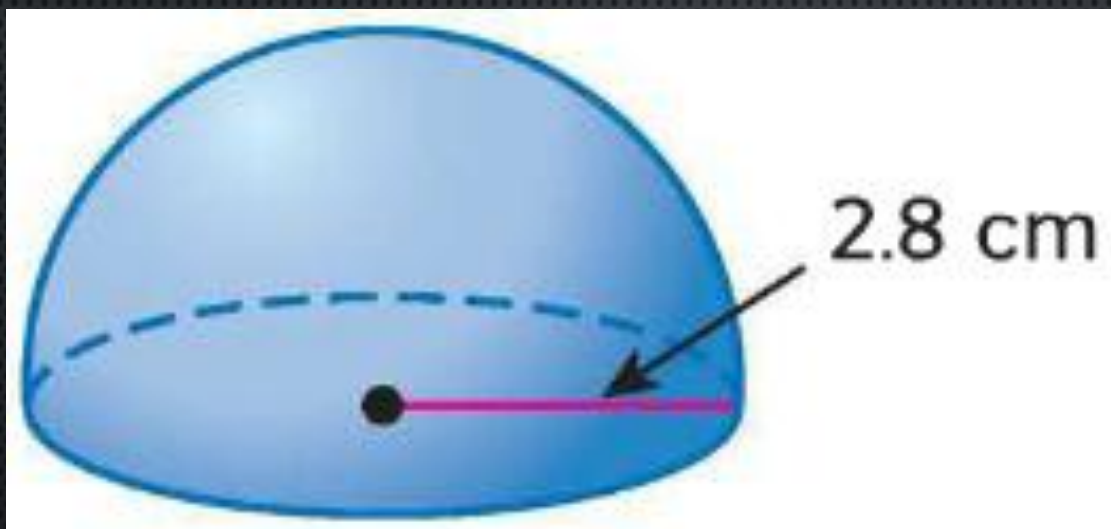

EXAMPLES

- FIND THE SURFACE AREA OF THE HEMISPHERE.

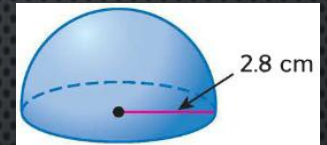

- $S = 2\pi R^2 + 2\pi R$ OR $S = 2\pi R(R + 1)$
- $S = 2\pi(2.8)(2.8 + 1) = 2\pi(2.8)(3.8)$
- $S = 21.28\pi = 66.85$

EXAMPLES

- FIND THE SURFACE AREA OF THE SPHERE.

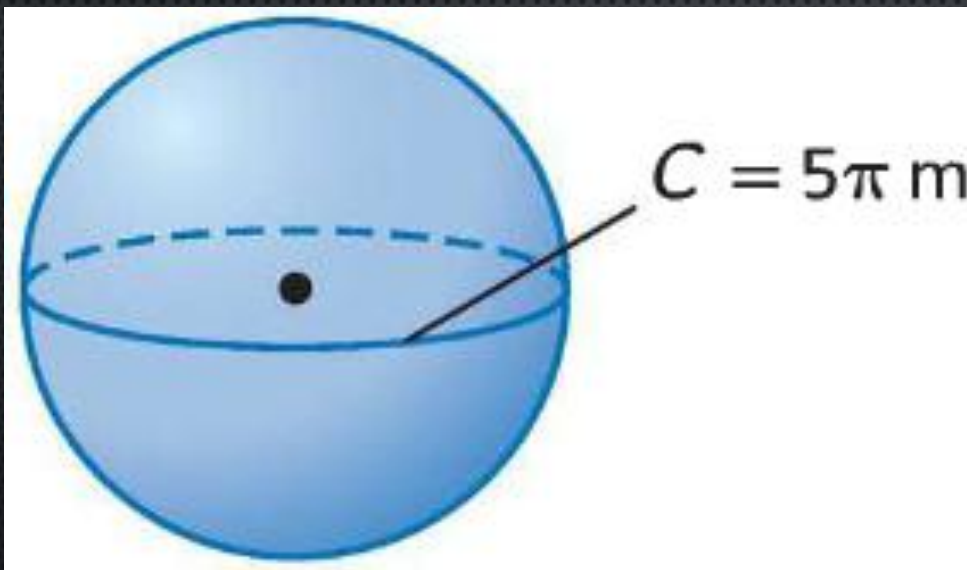

EXAMPLES

- FIND THE SURFACE AREA OF THE SPHERE.

- $S = 4\pi R^2; C = 2\pi R \rightarrow R = \frac{C}{2\pi} = \frac{5\pi}{2\pi} = 2.5$

- $S = 4\pi(2.5)^2 = 4\pi(6.25)$

- $S = 25\pi = 78.54$

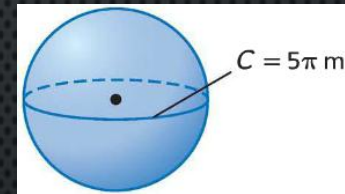

EXAMPLES

- FIND THE SURFACE AREA OF A SPHERE IF THE AREA OF THE GREAT CIRCLE IS APPROXIMATELY 130 SQUARE INCHES.

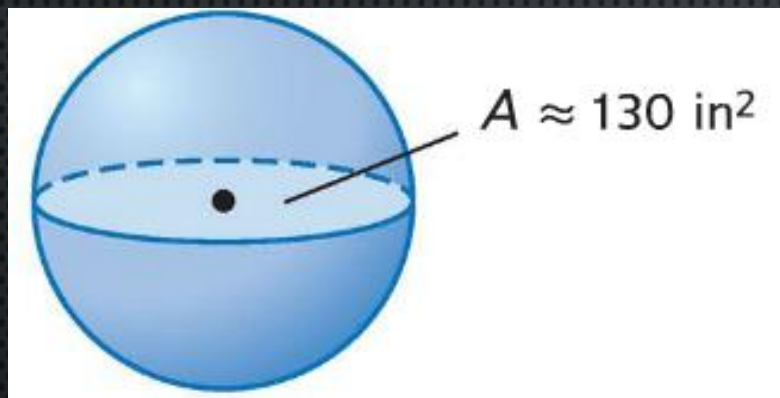

EXAMPLES

- FIND THE SURFACE AREA OF A SPHERE IF THE AREA OF THE GREAT CIRCLE IS APPROXIMATELY 130 SQUARE INCHES.
- $S = 4\pi R^2; \pi R^2 = 130$
- $S = 4 * 130 = 520$

